

Series 93/193 and Series 94/194 Low Water Cut-Off/Pump Controllers For Steam Boilers and Level Control Applications

Typical Applications:

- Primary or secondary pump controller/
low water fuel cut-off
for steam boilers
- Motorized valve controller
- Proportional valve controller
- Low water cut-off
- High water cut-off
- Alarm actuation

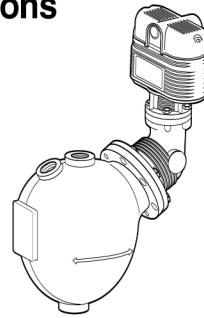

Series 93 or Series 94

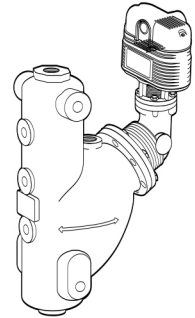

Series 193 or Series 194



WARNING

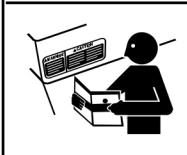

- Before using this product read and understand instructions.
- Save these instructions for future reference.



- All work must be performed by qualified personnel trained in the proper application, installation, and maintenance of plumbing, steam, and electrical and/or systems in accordance with all applicable codes and ordinances.
- To prevent serious burns, the boiler must be cooled to 80°F (27°C) and the pressure must be 0 psi (0 bar) before servicing.
- To prevent electrical shock, turn off the electrical power before making electrical connections.

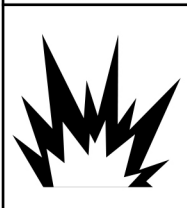

- This low water cut-off must be installed in series with all other limit and operating controls installed on the boiler. After installation, check for proper operation of all of the limit and operating controls, before leaving the site.
- We recommend that secondary (redundant) Low Water Cut-Off controls be installed on all steam boilers with heat input greater than 400,000 BTU/hour or operating above 15 psi of steam pressure. At least two controls should be connected in series with the burner control circuit to provide safety redundancy protection should the boiler experience a low water condition. Moreover, at each annual outage, the low water cut-offs should be dismantled, inspected, cleaned, and checked for proper calibration and performance.



- To prevent serious personal injury from steam blow down, connect a drain pipe to the control opening to avoid exposure to steam discharge.
- To prevent a fire, do not exceed the switch contact rating.
- This product can expose you to chemicals including Lead, which is known to the State of California to cause cancer and birth defects or other reproductive harm.
For more information go to: www.P65Warnings.ca.gov.
- Previous controls should never be installed on a new system. Always install new controls on a new boiler or system.

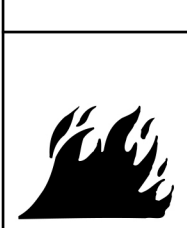

Failure to follow this warning could cause property damage, personal injury or death.

CAUTION:

- A more frequent replacement interval may be necessary based on the condition of the unit at time of inspection. McDonnell & Miller's warranty is one (1) year from date of installation or two (2) years from the date of manufacture.

OPERATION

Maximum Pressure:

Series 93/193: 150 psi (10.5 kg/cm²)

Series 94/194: 250 psi (17.6kg/cm²)

Electrical Ratings

Models with 5 or 5-M Switch

Voltage	Pump and Burner Switch Contact Ratings Pilot Duty Only
120 VAC	345 VA
240 VAC	

Models with 7B or 7B-M Switch

Switch Ratings		
Burner	Valve	
120 VAC	345 VA	0 - 135 ohms @ 24 VAC
240 VAC		

Switch Settings

Values are ± 1/8" (3mm)

Models with 5 or 5-M Switches

Setting	Approximate Distance Above Cast Line In. (mm)	Differential In. (mm)
Pump Off	2 ³ / ₁₆ (56)	1 ¹ / ₁₆ (27)
Pump On	1 ¹ / ₈ (29)	
Burner On	1 ³ / ₈ (35)	1 ³ / ₈ (35)
Burner Off	0	

Models with 7B or 7B-M Switches

Setting	Approximate Distance Above Cast Line In. (mm)	Differential In. (mm)
Valve Full Closed	2 ³ / ₁₆ (56)	1 ¹ / ₁₆ (27)
Valve Full Open	1 ¹ / ₈ (29)	
Burner On	1 ³ / ₈ (35)	1 ³ / ₈ (35)
Burner Off	0	

NOTE: Due to the slower operation of some motorized valves, complete valve opening or closing may occur at slightly different levels than indicated above.

INSTALLATION –

TOOLS NEEDED:

Two (2) pipe wrenches, one (1) flathead screw driver, and pipe sealing compound.

IMPORTANT: Follow the boiler manufacturer's instructions along with all applicable codes and ordinances for piping, blow-down valve, water gauge glass, tri-cock and electrical requirements.

STEP 1 - Determine the Position of the Low Water Cut-Off/Pump Controller

If the control will be the **primary low water fuel cut-off**, size the steam (top) and water (bottom) equalizing pipe lengths so that the horizontal cast line on the body is **1 1/2" (38mm) below the boiler's normal water level**, but not lower than the lowest safe permissible water level, as determined by the boiler manufacturer.

OR

If the control will be the **secondary low water fuel cut-off**, size the steam (top) and water (bottom) equalizing pipe lengths so that the horizontal cast line on the body is **at or above the lowest safe permissible water level**, as determined by the boiler manufacturer.

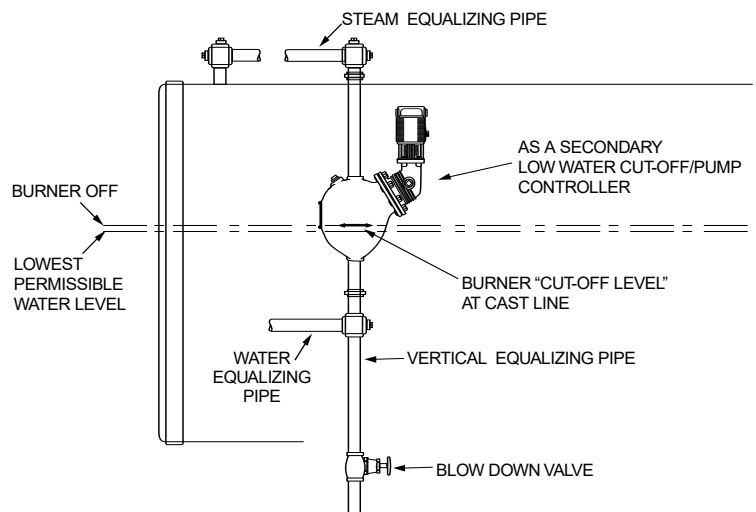
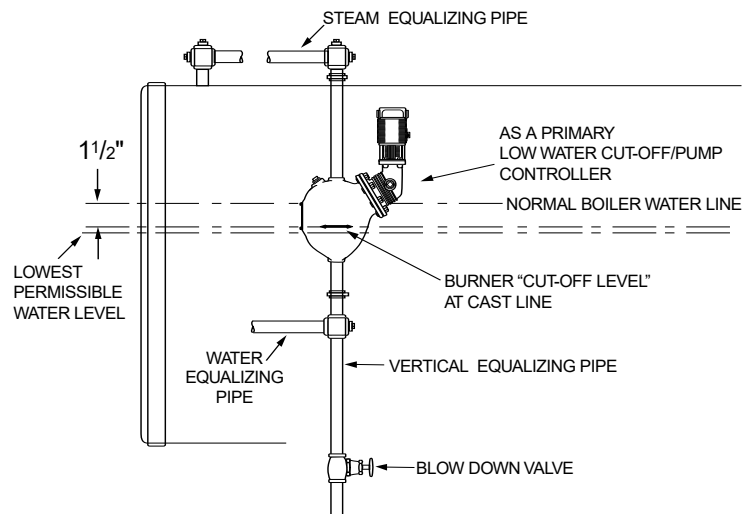

STEP 2 - Installing the Low Water Cut-Off/Pump Controller For Series 93/193 or 94/194 (except 94-A, 193-D and 193-G Models)

- a. Mount and pipe the control (A) on vertical equalizing pipes (B) at the required elevation as determined in Step 1.

Install a full-ported blow-down valve (C) directly below the lower cross.

NOTE:

1" NPT tappings are provided on Series 93/193 controls.

1 1/4" NPT tappings are provided for Series 94/194 controls and 193-B Model.

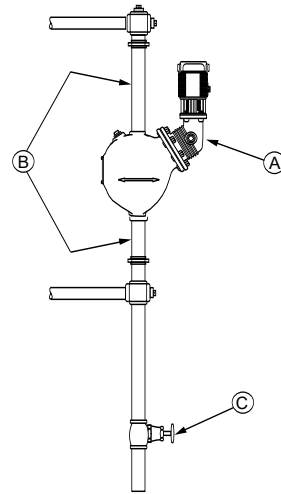

For 94-A and 193-G Models

- a. Mount and pipe the control (A) with a vertical upper (D) and horizontal lower (E) equalizing piping at the required elevation as determined in Step 1.

Install a full-ported blow-down valve (C) on the lower body connection.

NOTE:

1 1/4" NPT tappings are provided for 94-A Model control.

1" NPT tappings are provided for 193-G Model control.

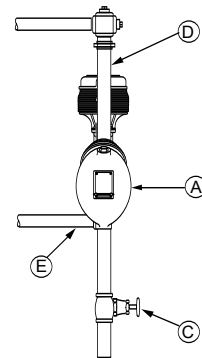

For 193-D Models

- a. Mount and pipe the control (A) with a horizontal upper and lower (G) equalizing piping at the required elevation as determined in Step 1.

Install a full-ported blow-down valve (C) on the lower body connection.

NOTE:

1" NPT tappings are provided for 193-D Model control.

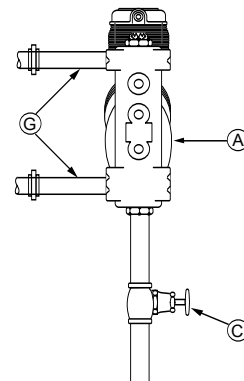

STEP 3 - Removing Float Blocking Plugs and Dowels

CAUTION

The plug and rod must be reinstalled before control is shipped installed on the boiler, and removed after boiler is placed and installed.

Failure to follow this caution may damage the float and operating mechanism.

- a. Using a pipe wrench, remove the float blocking plugs (I) and dowels (H) from the control as shown below.
- b. Using a pipe wrench, screw the pipe plugs provided with control into the open tappings.

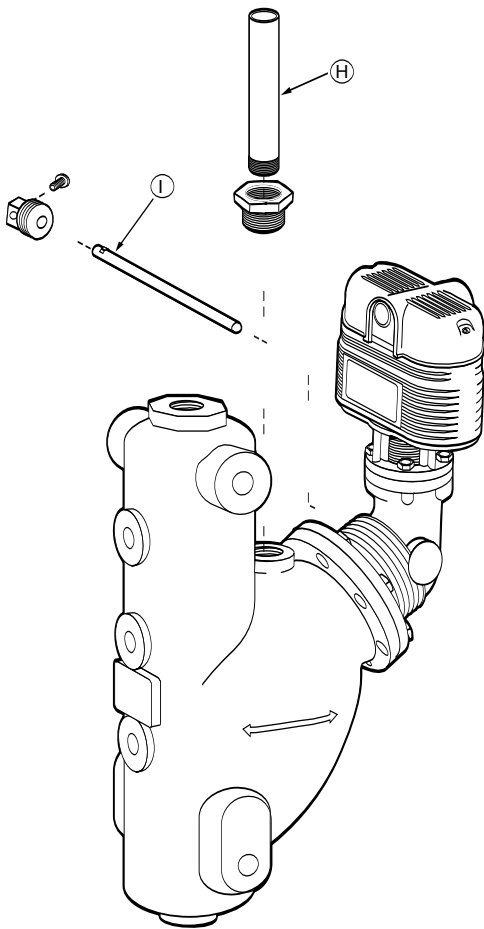

Series 193 / 194

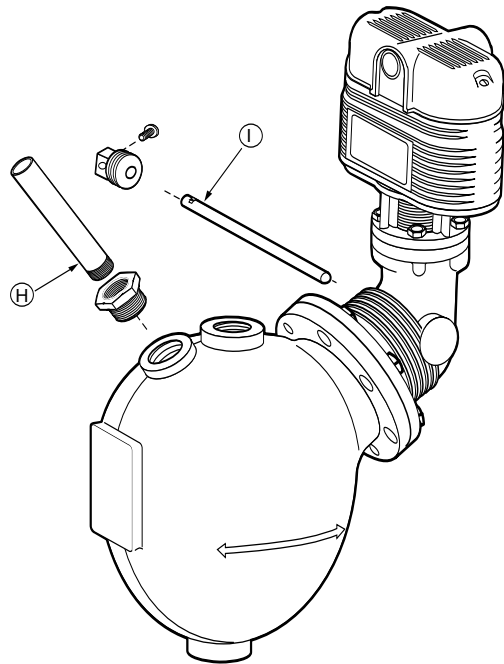

Series 93 / 94

STEP 4 - Installing a Water Gauge Glass and Tri-Cocks

NOTE: A separate water column for installation of gauge glass and tri-cocks may be required for boilers with a Series 93 or Series 94 control. Follow the manufacturer's instruction to install the water column.

- a. Determine pipe size of tri-cock and sight glass tapings for the control being installed including center distance of sight glass tapings.

NOTE:

These items are not provided with control and must be purchased separately

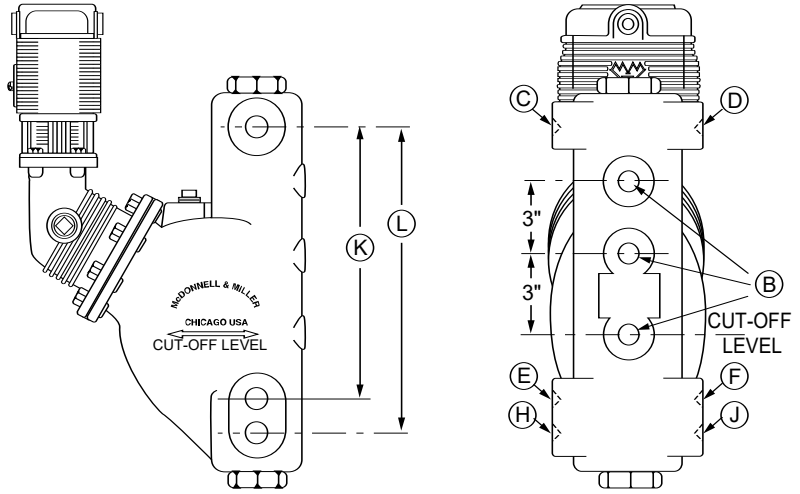

Unit	Tri-Cock Tapping		Gauge Glass Tapping Pipe Size				Gauge Glass Tapping Center Distance		
	B	C	D	E	F	H	J	K	L
193	1/2	1/2	1/2			1/2	1/2		12 3/4 (324)
193-A	1/2	1/2	1/2	1/2	1/2			11 1/2 (292)	
193-B	3/4	3/4	3/4			3/4	3/4		12 3/4 (324)
193-D	1/2		1/2		1/2			11 1/2 (292)	
193-G	1/2		1/2		1/2			11 1/2 (292)	
194	1/2	1/2	1/2	1/2	1/2			11 5/8 (295)	
194-A	1/2	1/2	1/2			1/2	1/2		12 7/8 (327)
194-B	3/4	3/4	3/4			3/4	3/4		12 7/8 (327)

- b. Install tri-cocks and gauge glass following manufacturer's instructions.

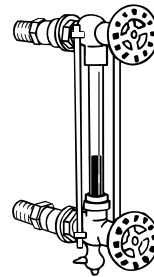

GAUGE GLASS
(TYPICAL)

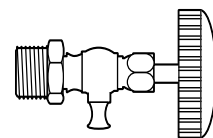

TRI-COCK
(TYPICAL)

STEP 5 - Electrical Wiring

⚠ WARNING



- To prevent electrical shock, turn off the electrical power before making electrical connections.
- This low water cut-off must be installed in series with all other limit and operating controls installed on the boiler. After installation, check for proper operation of all of the limit and operating controls, before leaving the site.



Failure to follow this warning could cause electrical shock, an explosion and/or a fire, which could result in property damage, personal injury or death.

Wiring Diagrams

NOTE: The following diagrams are provided for reference only. If available, manufacturer's wiring diagrams should always be followed to connect the device being operated.

Switch Operation

For Series 93/193 or 94/194 with 5 or 5-M Switch

Red switch terminals 1 and 2 are for burner circuit contacts, terminals 3 and 4 are for the low level alarm circuit contacts.

Blue switch terminals 3 and 4 are for feeder/pump control contacts, terminals 1 and 2 are for high level alarm circuit contacts.

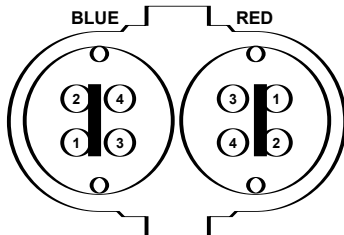

BOILER FEED PUMP OFF-
BURNER ON-ALARM OFF

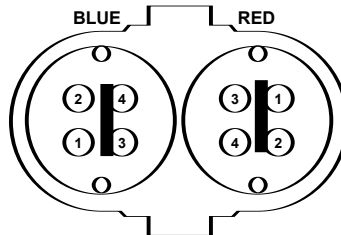

BOILER FEED PUMP ON-
BURNER ON-ALARM OFF

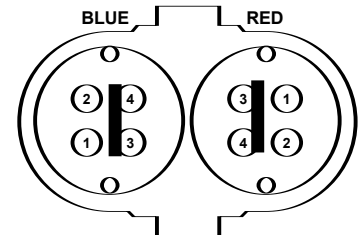

BOILER FEED PUMP ON-
BURNER OFF-ALARM ON

Pump Control, Low Water Cut-Off and Alarm

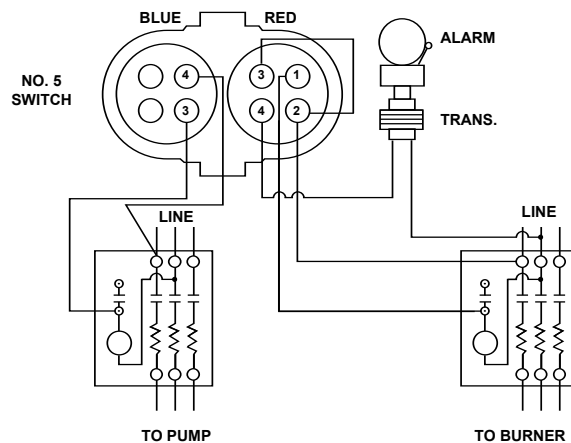

Low Water Cut-Off Only

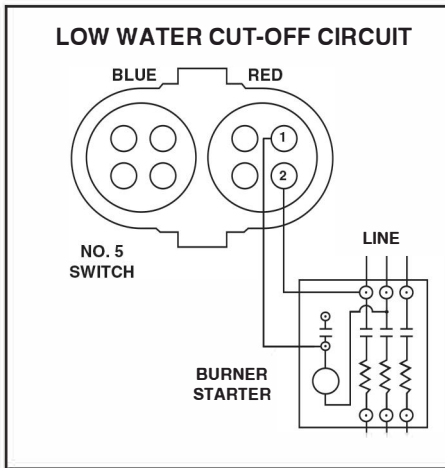

Pump Control Only

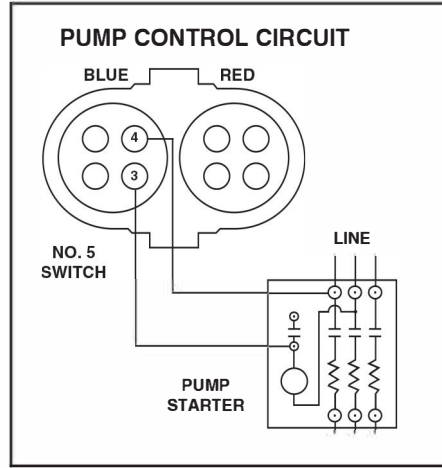

Low Water Alarm Only

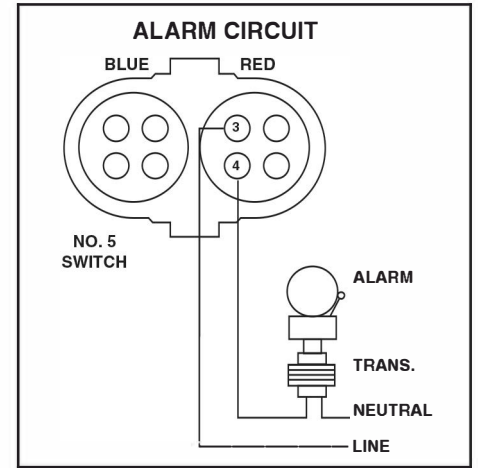

For Series 93/193 or 94/194 with 7B or 7B-M

Red terminals 1 and 2 are the burner circuit contacts, terminals 3 and 4 are the low level alarm circuit contacts.

Blue terminal 3 is the common contact, terminals 1 and 4 are the output contacts.

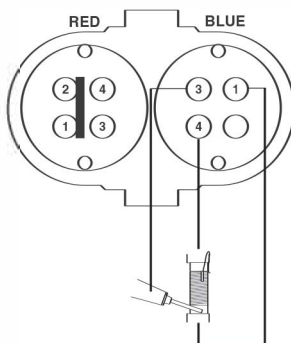

BURNER ON-ALARM OFF
VALVE CLOSED

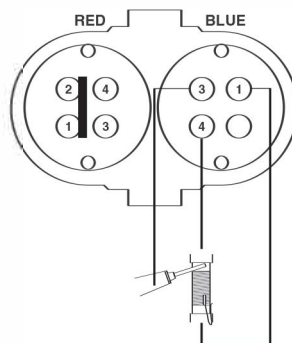

BURNER ON-ALARM OFF
VALVE OPEN

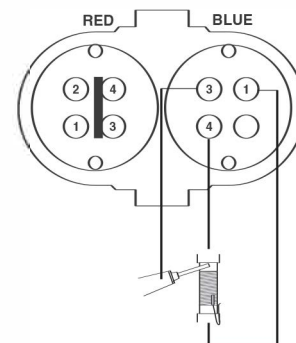

BURNER OFF-ALARM ON
VALVE OPEN

NOTE: The 7B switch is a 135 ohm potentiometer slide wire control for use with an electric valve operator with the same rating.

Proportional Control, Low Water Cut-Off and Alarm

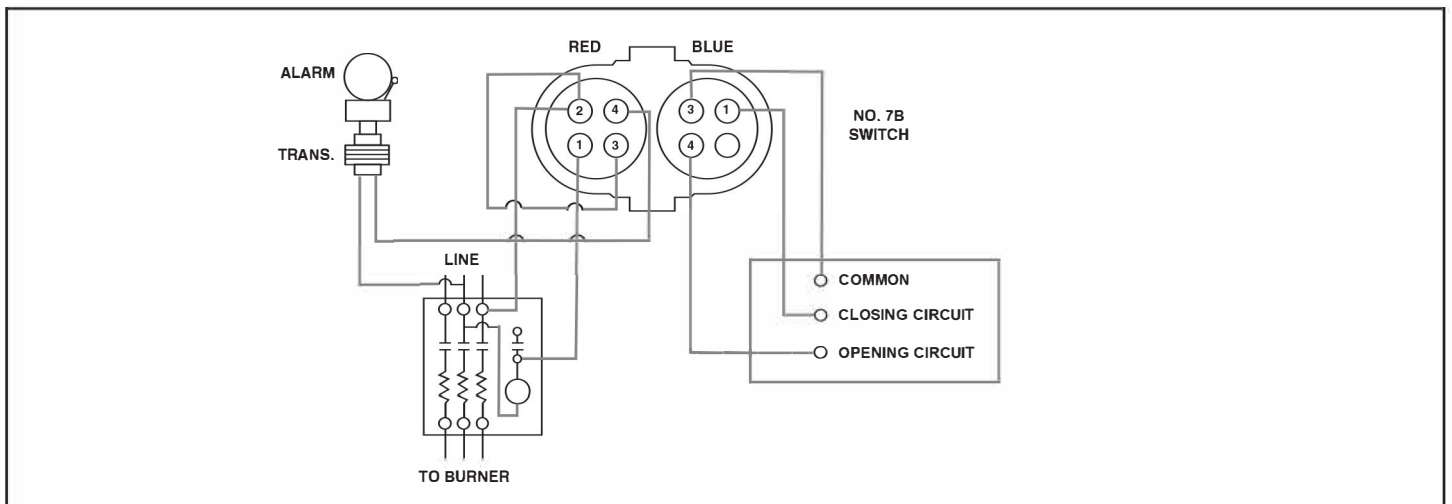

Wiring Connections

- a. Remove two screws (A) and lift off switch cover.

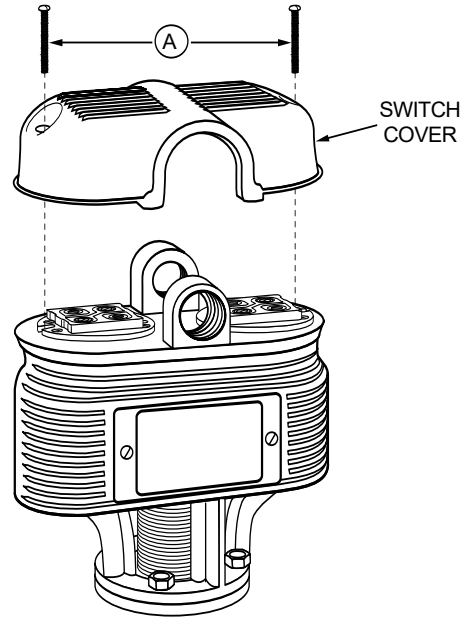

- b. Connect BX armored cable or Thinwall electrical metal tubing to the integral fitting hub. Connect wires to terminals following appropriate wiring diagram from pages 7 and 8 for your application.

NOTE: Follow local codes and standards when selecting the types of electrical fittings and conduit to connect to control.

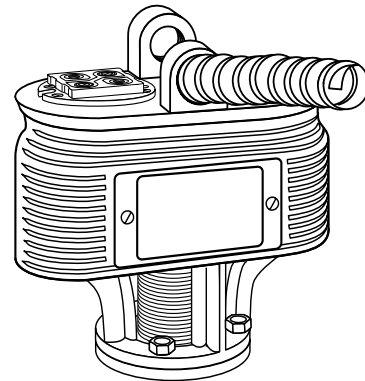

- c. Replace switch cover and fasten with two screws (A).

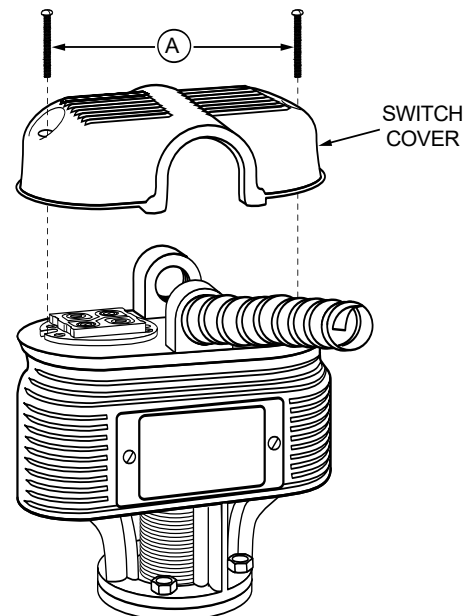

STEP 6 - Testing

- Dimensions provided are typical.
- The following testing procedure is only meant to serve as a verification of proper operating sequence.

a. Turn on power to boiler and pump circuits.

With the boiler empty, the pump should turn on (5 or 5-M switch models) or the valve open (7B or 7B-M switch models). The burner should remain off and boiler should begin to fill with water.

CAUTION

Immediately turn off all power if the burner turns on with no water in the gauge glass. Investigate further before continuing procedure.

b. For Automatic Reset Models

When water level in the gauge glass is approximately 1 3/8" (35mm) above the horizontal cast line, the burner should turn on.

For Manual Reset Models

When water level in the gauge glass is approximately 1 3/8" (35mm) above the horizontal cast line, press the manual reset button and the burner should turn on.

c. For 5 or 5-M Switch Models

When water level in the gauge glass is approximately 2 3/16" (56mm) above the horizontal cast line, the pump should turn off.

For 7B or 7B-M Switch Models

When water level in the gauge glass is approximately 2 3/16" (56mm) above the horizontal cast line, the valve should be closed.

CAUTION

If pump does not turn off or valve close, turn off water supply to boiler. Investigate further before continuing procedure.

- d. With the water in the boiler at its normal level and burner on, SLOWLY open the blow-down valve until it is fully open. As the water level in the gauge glass begins to drop, verify that the following occurs.

For 5 or 5-M Switch Models

When water level drops to approximately 1 1/8" (29mm) above the horizontal cast line, the pump should turn on. When water level drops to the horizontal cast line, the burner should turn off.

For 7B or 7B-M Switch Models

As the water level drops, the valve should begin to open. When the water level drops to approximately 1 1/8" (29mm) above the horizontal cast line, the valve should be full open. When the water level drops to the horizontal cast line, the burner should turn off.

- e. Close the blow-down valve after burner turns off and restore water level to normal operating level.
- f. Repeat testing procedure several times to ensure proper operation of control.
- g. After testing and verification of control operation, the boiler can be returned to service.

TROUBLESHOOTING

Erratic operation of the control is the most common symptom that occurs. Erratic operation can be defined as pump and/or burner switches not switching at proper levels. Refer to the following list of items to check if the control is not operating properly.

1. Float Ball is Crushed

Crushed floats are typically caused by improper blow-down. Drain piping from blow-down valve to drain should be checked for proper pitch and the blow-down procedure followed when blowing down the control. Purchase and install a new float ball after investigating and correcting the problem.

2. Float Ball is Filled with Water

The seam weld on the float can sometimes deteriorate. This can be caused by the type of chemical treatment used in the boiler. While this is a rare occurrence, the chemical treatment supplier should be consulted to determine if a reaction could occur. Purchase and install a new float ball after investigating and correcting the problem.

3. Float Arm Springs are Bent

The pivot springs located on either side of the float rod should be flat and straight. If they become bent, the usual cause is mishandling of the unit during installation or improper blow-down. The control should never be picked up by the float ball or allowed to hang from the bowl by the float. Drain piping from blow-down valve to drain should be checked for proper pitch and the blow-down procedure followed when blowing down control. Purchase and install new control or head mechanism after investigating and correcting the problem.

4. Switch Contact Springs Broken

The contact springs can break if the electrical rating is exceeded. Purchase and install new switch assembly or head mechanism after investigating and correcting the problem.

5. Switch Contact Springs Misaligned

Misalignment of the contact arms is usually associated with damage to the control during shipment or installation. Purchase and install new switch assembly or head mechanism after investigating and correcting the problem.

6. Internal (Wetted) Parts Dirty

The internal parts can operate improperly if dirt, scale or rust is allowed to build. This condition can be a result of not blowing down the control as recommended and/or improper boiler water chemical treatment. Purchase and install new control or head mechanism after investigating and correcting the problem.

MAINTENANCE

SCHEDULE:

Blow down control as follows when boiler is in operation.

- Daily if operating pressure is above 15 psi.
- Weekly if operating pressure is below 15 psi.

⚠ NOTE
More frequent blow-down may be necessary due to dirty boiler water and/or local codes.

⚠ NOTE
High levels of chlorides in the boiler water can increase the rate of corrosion in the water-wetted components of the control.
Contact your boiler manufacturer and follow their recommendations on controlling boiler water quality.

⚠ NOTE
The control may need to be inspected and cleaned more frequently on systems where there is the potential of excessive scale or sludge build-up. This includes systems:
<ul style="list-style-type: none"> • With high raw water make-up • With no condensate return • With untreated boiler water • Where significant changes have been made to the boiler-water chemical treatment process • With oil in the boiler water

- **Remove head assembly and inspect water side components annually.** Replace head assembly if any of the internal components are worn, corroded or damaged or if control no longer operates properly.
- **Inspect the float chamber and equalizing piping annually.** Remove all sediment and debris.

Replace head mechanism every 5 years.

More frequent replacement may be required when severe conditions exist.

Replacement parts are available from your local authorized McDonnell & Miller Distributor.

The use of parts or components other than those manufactured by McDonnell & Miller will void all warranties and may affect the units compliance with listings or regulating agencies.

BLOW DOWN PROCEDURE:

⚠ CAUTION	
	To prevent serious personal injury from steam pipe blow down, connect a drain pipe to the control opening to avoid exposure to steam discharge.
	Failure to follow this caution could cause personal injury.

When blowing down a control at pressure, the blow down valves should be opened slowly. The piping needs to be warmed up and stagnant water in the drain piping needs to be pushed out. Suddenly opening a blow down valve causes steam to condense, which creates water hammer. Damage to components can occur when water hammer occurs due to improper blow down piping. For these reasons, McDonnell & Miller recommends a dual valve blow-down system for each control.

Blow down the control when the water in the boiler is at its normal level and the burner is on.

NOTE: Refer to page 2 for switch operating points.

- Open upper valve (#1)
- Slowly open the lower valve (#2)
- Water in the sight glass should lower.
- As the water in the sight glass lowers, the pump should turn on.
- As the water continues to lower in the sight glass, the burner should turn off.
- Slowly close the lower valve (#2).
- Close the upper valve (#1)
- The water level in the sight glass should rise, first turning on the burner and then turning off the pump.

NOTE: On manual reset models, the reset button will need to be pressed after the water level has been restored before the burner will operate.

⚠ NOTE
If this sequence of operation does not occur as described, immediately close all the valves, turn off the boiler and correct the problem. Inspection/cleaning of the float mechanism may be required to determine why the control was not working properly. Retest the control after the problem has been identified and corrected.

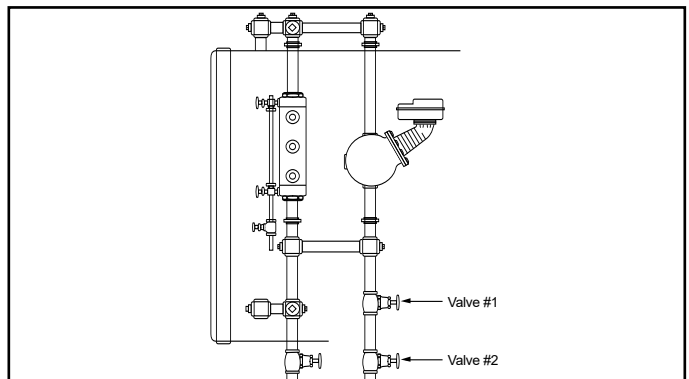

COMMERCIAL WARRANTY

Warranty. For goods sold to commercial buyers, Seller warrants the goods sold to Buyer hereunder (with the exception of membranes, seals, gaskets, elastomer materials, coatings and other "wear parts" or consumables all of which are not warranted except as otherwise provided in the quotation or sales form) will be (i) be built in accordance with the specifications referred to in the quotation or sales form, if such specifications are expressly made a part of this Agreement, and (ii) free from defects in material and workmanship for a period of one (1) year from the date of installation or two (2) years from the date of manufacture, whichever shall occur first, unless a longer period is specified in the product documentation (the "Warranty").

Except as otherwise required by law, Seller shall, at its option and at no cost to Buyer, either repair or replace any product which fails to conform with the Warranty provided Buyer gives written notice to Seller of any defects in material or workmanship within ten (10) days of the date when any defects or non-conformance are first manifest. Under either repair or replacement option, Seller shall not be obligated to remove or pay for the removal of the defective product or install or pay for the installation of the replaced or repaired product and Buyer shall be responsible for all other costs, including, but not limited to, service costs, shipping fees and expenses. Seller shall have sole discretion as to the method or means of repair or replacement. Buyer's failure to comply with Seller's repair or replacement directions shall terminate Seller's obligations under this Warranty and render the Warranty void. Any parts repaired or replaced under the Warranty are warranted only for the balance of the warranty period on the parts that were repaired or replaced. Seller shall have no warranty obligations to Buyer with respect to any product or parts of a product that have been: (a) repaired by third parties other than Seller or without Seller's written approval; (b) subject to misuse, misapplication, neglect, alteration, accident, or physical damage; (c) used in a manner contrary to Seller's instructions for installation, operation and maintenance; (d) damaged from ordinary wear and tear, corrosion, or chemical attack; (e) damaged due to abnormal conditions, vibration, failure to properly prime, or operation without flow; (f) damaged due to a defective power supply or improper electrical protection; or (g) damaged resulting from the use of accessory equipment not sold or approved by Seller. In any case of products not manufactured by Seller, there is no warranty from Seller; however, Seller will extend to Buyer any warranty received from Seller's supplier of such products.

THE FOREGOING WARRANTY IS EXCLUSIVE AND IN LIEU OF ANY AND ALL OTHER EXPRESS OR IMPLIED WARRANTIES, GUARANTEES, CONDITIONS OR TERMS OF WHATEVER NATURE RELATING TO THE GOODS PROVIDED HEREUNDER, INCLUDING WITHOUT LIMITATION ANY IMPLIED WARRANTIES OF MERCHANTABILITY AND FITNESS FOR A PARTICULAR PURPOSE, WHICH ARE HEREBY EXPRESSLY DISCLAIMED AND EXCLUDED. EXCEPT AS OTHERWISE REQUIRED BY LAW, BUYER'S EXCLUSIVE REMEDY AND SELLER'S AGGREGATE LIABILITY FOR BREACH OF ANY OF THE FOREGOING WARRANTIES ARE LIMITED TO REPAIRING OR REPLACING THE PRODUCT AND SHALL IN ALL CASES BE LIMITED TO THE AMOUNT PAID BY THE BUYER FOR THE DEFECTIVE PRODUCT. IN NO EVENT SHALL SELLER BE LIABLE FOR ANY OTHER FORM OF DAMAGES, WHETHER DIRECT, INDIRECT, LIQUIDATED, INCIDENTAL, CONSEQUENTIAL, PUNITIVE, EXEMPLARY OR SPECIAL DAMAGES, INCLUDING BUT NOT LIMITED TO LOSS OF PROFIT, LOSS OF ANTICIPATED SAVINGS OR REVENUE, LOSS OF INCOME, LOSS OF BUSINESS, LOSS OF PRODUCTION, LOSS OF OPPORTUNITY OR LOSS OF REPUTATION.

LIMITED CONSUMER WARRANTY

Warranty. For goods sold for personal, family or household purposes, Seller warrants the goods purchased hereunder (with the exception of membranes, seals, gaskets, elastomer materials, coatings and other "wear parts" or consumables all of which are not warranted except as otherwise provided in the quotation or sales form) will be free from defects in material and workmanship for a period of one (1) year from the date of installation or two (2) years from the product date code, whichever shall occur first, unless a longer period is provided by law or is specified in the product documentation (the "Warranty").

Except as otherwise required by law, Seller shall, at its option and at no cost to Buyer, either repair or replace any product which fails to conform with the Warranty provided Buyer gives written notice to Seller of any defects in material or workmanship within ten (10) days of the date when any defects or non-conformance are first manifest. Under either repair or replacement option, Seller shall not be obligated to remove or pay for the removal of the defective product or install or pay for the installation of the replaced or repaired product and Buyer shall be responsible for all other costs, including, but not limited to, service costs, shipping fees and expenses. Seller shall have sole discretion as to the method or means of repair or replacement. Buyer's failure to comply with Seller's repair or replacement directions shall terminate Seller's obligations under this Warranty and render this Warranty void. Any parts repaired or replaced under the Warranty are warranted only for the balance of the warranty period on the parts that were repaired or replaced. The Warranty is conditioned on Buyer giving written notice to Seller of any defects in material or workmanship of warranted goods within ten (10) days of the date when any defects are first manifest.

Seller shall have no warranty obligations to Buyer with respect to any product or parts of a product that have been: (a) repaired by third parties other than Seller or without Seller's written approval; (b) subject to misuse, misapplication, neglect, alteration, accident, or physical damage; (c) used in a manner contrary to Seller's instructions for installation, operation and maintenance; (d) damaged from ordinary wear and tear, corrosion, or chemical attack; (e) damaged due to abnormal conditions, vibration, failure to properly prime, or operation without flow; (f) damaged due to a defective power supply or improper electrical protection; or (g) damaged resulting from the use of accessory equipment not sold or approved by Seller. In any case of products not manufactured by Seller, there is no warranty from Seller; however, Seller will extend to Buyer any warranty received from Seller's supplier of such products.

THE FOREGOING WARRANTY IS PROVIDED IN PLACE OF ALL OTHER EXPRESS WARRANTIES. ALL IMPLIED WARRANTIES, INCLUDING BUT NOT LIMITED TO THE IMPLIED WARRANTIES OF MERCHANTABILITY AND FITNESS FOR A PARTICULAR PURPOSE, ARE LIMITED TO ONE (1) YEAR FROM THE DATE OF INSTALLATION OR TWO (2) YEARS FROM THE PRODUCT DATE CODE, WHICHEVER SHALL OCCUR FIRST. EXCEPT AS OTHERWISE REQUIRED BY LAW, BUYER'S EXCLUSIVE REMEDY AND SELLER'S AGGREGATE LIABILITY FOR BREACH OF ANY OF THE FOREGOING WARRANTIES ARE LIMITED TO REPAIRING OR REPLACING THE PRODUCT AND SHALL IN ALL CASES BE LIMITED TO THE AMOUNT PAID BY THE BUYER FOR THE DEFECTIVE PRODUCT. IN NO EVENT SHALL SELLER BE LIABLE FOR ANY OTHER FORM OF DAMAGES, WHETHER DIRECT, INDIRECT, LIQUIDATED, INCIDENTAL, CONSEQUENTIAL, PUNITIVE, EXEMPLARY OR SPECIAL DAMAGES, INCLUDING BUT NOT LIMITED TO LOSS OF PROFIT, LOSS OF ANTICIPATED SAVINGS OR REVENUE, LOSS OF INCOME, LOSS OF BUSINESS, LOSS OF PRODUCTION, LOSS OF OPPORTUNITY OR LOSS OF REPUTATION.

Some states do not allow limitations on how long an implied warranty lasts, so the above limitation may not apply to you. Some states do not allow the exclusion or limitation of incidental or consequential damages, so the above exclusions may not apply to you. This warranty gives you specific legal rights, and you may also have other rights which may vary from state to state.

To make a warranty claim, check first with the dealer from whom you purchased the product or call +1-847-966-3700 for the name and location of the nearest dealer providing warranty service.

xylem
Let's Solve Water

Xylem Inc.
8200 N. Austin Avenue
Morton Grove, Illinois 60053
Phone: (847) 966-3700
Fax: (847) 965-8379
www.xylem.com/mcdonnellmiller

McDonnell & Miller is a trademark of Xylem Inc. or one of its subsidiaries.
© 2023 Xylem Inc. MM-4040 October 2023 Part No. 246043

