

Description

EVO-Z is a self-acting, adjustable, non-electric thermostatic operator and remote temperature sensor. It has adjustable max./min. temperature, selected temperature locking feature and can be shutoff completely if required. The symbol * protects against frost damage. Each EVO-Z thermostatic operator is individually calibrated and conforms to ASHRAE standardization rules for temperature regulation. The EVO-Z's smooth shape and narrow air gaps gives a nice operation and makes it easy to keep clean. They can be mounted on all Macon NT series valves.

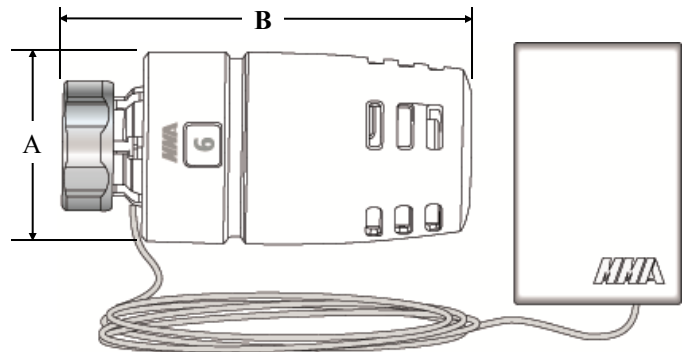

NON-ELECTRIC OPERATORS



TECHNICAL DATA					
Temperature Setting Range	50°F to 82°F	Material	Engineered heat resistant thermoplastic (PBT,POM)		
Maximum Storage & Ambient Temp.	122°F				
Maximum Water Temp.	250°F			Nut	Low Lead Brass
Maximum Steam Pressure	15 psig			Weight	4.16 oz.
Maximum Differential Pressure	20 psi			Color	White
Suggested Differential Pressure	0.5 to 2.9 psi			Width (A)	1.73"
Max. Movement	0.125"			Height (B)	3.66"
Nominal Opening	0.018 (3.6°F)			Capillary Length	6' 6"
Long Term Test	5000 Cycles (1.3°F)				

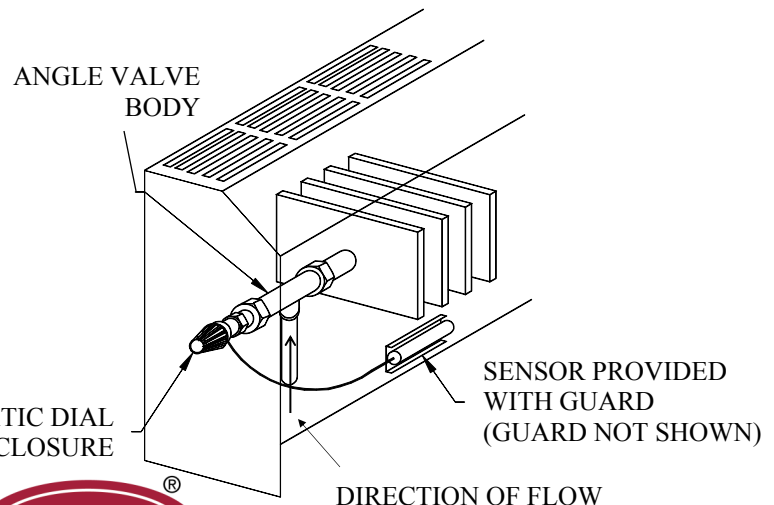
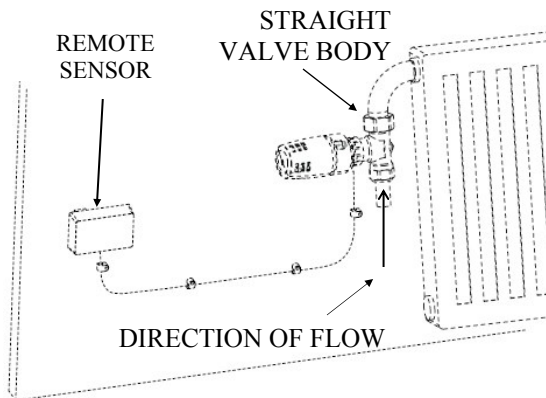

THERMOSTATIC DIAL INSIDE ENCLOSURE



Maximum & Minimum Setting

Maximum setting

1. Turn the wheel to maximum.
2. Push the mark in with limit tool (located opposite the dial setting window) and press in the wheel handle 1-2 mm until it stops. (Figure 1)
3. Remove the limit tool and press in the wheel handle until it stops. (Figure 2)
4. Set the required temperature according to the chart below.
5. Pull the wheel handle out and the maximum temperature is set. (Figure 3)

Minimum setting

1. Turn the wheel to minimum
2. Push the mark in with limit tool (located opposite the dial setting window) and press in the wheel handle 1-2 mm until it stops.
3. Remove the limit tool and press in the wheel handle until it stops.
4. Set the required temperature according to the chart below.
5. Pull the wheel handle out and the minimum temperature is set.

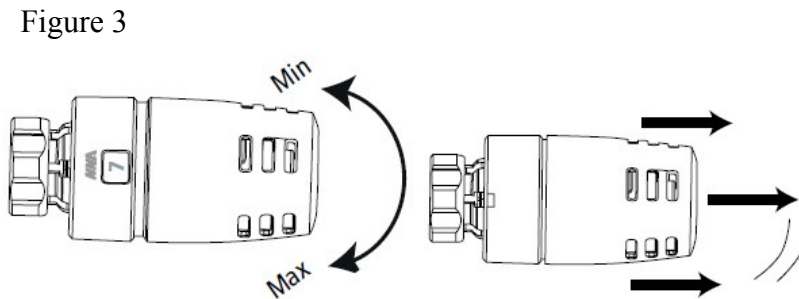
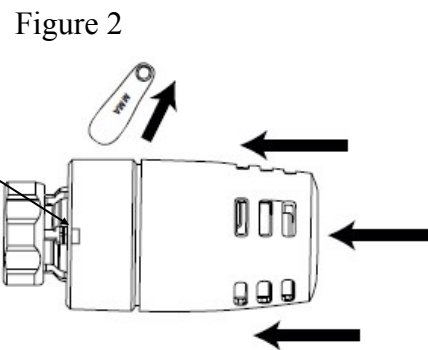
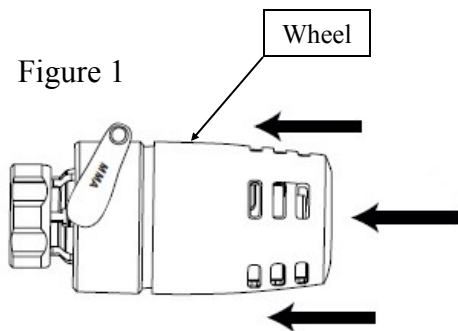

DIAL SETTINGS								
0	*	1	3	5	6	7	8	9
Off	50	54	61	68	72	75	79	82
	Frost Protection							

