

## Low Water Cut-Offs – Mechanical Combination Low Water Cut-Off/Pump Controllers for Steam Boilers

### Series 194



### Low Water Cut-Off/Pump Controllers

- For commercial, and industrial low or high pressure steam boilers
- Maintains consistent water level regardless of pressure
- For boilers of any steaming capacity
- Water column with integral tappings for gauge glass and tri-cock installations
- No. 5 Switch included
- Magnetic repulsion eliminates need for bellows
- Optional features
  - Manual reset
  - 7B switch proportional 0-135 ohm control to maintain constant boiler water level
- 1 1/4" NPT connections
- Maximum pressure 250 psi (17.6 kg/cm<sup>2</sup>)
- Ten bolt flange

### Electrical Ratings

345 VA at 120 or 240 VAC

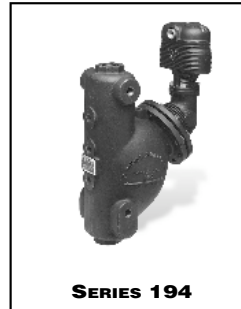

**SERIES 194**

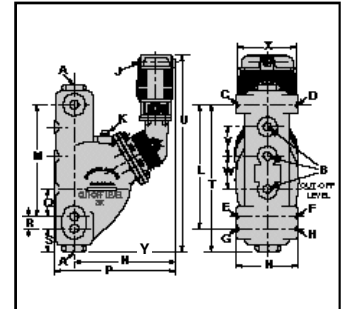

### Ordering Information

Model Number	Part Number	Description	Weight lbs. (kg)
194	166600	Combination low water cut-off/pump controller w/Series 5 switch	72.0 (32.7)
194-A	166700	194 w/alternate tappings	72.0 (32.7)
194-A-7B	167100	194-A w/Series 7B switch	72.0 (32.7)
194-M	166900	194 w/manual reset	72.0 (32.7)
194-7B	167200	194 w/Series 7B switch	72.0 (32.7)
194-7BM	167300	194-7B w/manual reset	72.0 (32.7)
194-B	166701	194 w/alternate tappings	72.0 (32.7)

### Dimensions, in. (mm)

Model	A NPT	B NPT	C NPT	D NPT	E NPT	F NPT	G NPT	H NPT	J NPT	K NPT
194	1 1/4	1/2	1/2	1/2	1/2	1/2	–	–	1/2	3/4
194-A	1 1/4	1/2	1/2	1/2	–	–	1/2	1/2	1/2	3/4
194-B	1 1/4	3/4	3/4	3/4	–	–	3/4	3/4	1/2	3/4

Model	L	M	N	P	Q	R	S
194	–	11 5/8 (295)	6 3/4 (171.4)	13 1/16 (332)	2 13/16 (71)	1 1/4 (32)	2 3/8 (60)
194-A	12 7/8 (327)	–	6 3/4 (171.4)	13 1/16 (332)	2 13/16 (71)	1 1/4 (32)	2 3/8 (60)
194-B	12 7/8 (327)	–	6 3/4 (171.4)	13 1/16 (332)	2 13/16 (71)	1 1/4 (32)	2 3/8 (60)

Model	T	U	V	W	X	Y
194	17 1/4 (438)	20 1/2 (521)	3 (76)	3 (76)	6 (152)	10 13/16 (274)
194-A	17 1/4 (438)	20 1/2 (521)	3 (76)	3 (76)	6 (152)	10 13/16 (274)
194-B	17 1/4 (438)	20 1/2 (521)	3 (76)	3 (76)	6 (152)	10 13/16 (274)